

Specification For Delivery



CUSTOMER

—

PART NUMBER

XSD-0503000NEKU

A0

Customer Approval			
担当者	审核	承认	公司承认章

SALES



品名

P/N

XS-S2205020

ENGINEER



RESPONSIBILITY



Table of contents

SAFETY STANDARD.....	P3
INPUT CHARACTERIST.....	P3
OUTPUT CHARACTERIST.....	P4
PROTECTION FUNCTION.....	P5
ENVIRONMENTAL REQUIREMET.....	P5、 6
EMC STANDARDS.....	P7
MAJOR MEASURE EQUIPMENT.....	P7
PRODUCT OUTLINE	P8
DC CORD.....	P9
RATING LABEL.....	P10
PACRING.....	P11

UPDATE REV.

REV	UPDATE	DATE	PRERARATOR
original		2022.05.09	陈海英



1、SAFETY STANDARD:

1.1 The green mode power supply shall be certified by the following international regulatory standards:

<input type="checkbox"/>		Country	CertifiedStatus	Standard / 標準
<input type="checkbox"/>	PSE	Japan	APPROVED	J62368, J55022
<input type="checkbox"/>	UL	USA	APPROVED	UL 62368-1: 2007
<input type="checkbox"/>	cUL	CAN	APPROVED	CAN/CSA-C22.2 No. 62368-1 (2007)
<input type="checkbox"/>	FCC	USA	APPROVED	Part 15 Class B
<input type="checkbox"/>	CE	Europe	APPROVED	EN 55032:55035/EN 62368-1/EN 61558-1/EN 61558-2-16
<input type="checkbox"/>	GS	Europe	APPROVED	EN 62368-1/EN 61558-1/EN 61558-2-16/AfPGS 21
<input type="checkbox"/>	BS	UK	APPROVED	BS EN 62368-1/BS EN 61558-1/BS EN 61558-2-16
<input type="checkbox"/>	SAA	Australia	APPROVED	AS/NZS 62368-1:2011& AS/NZS 3112:2011
<input type="checkbox"/>	CCC	CN	APPROVED	GB4943-2001,GB1317625.1-2003
<input checked="" type="checkbox"/>	KC	KC	APPROVED	HU10898-16001C

2、INPUT CHARACTERIST:

2.1

INPUT VOLTAGE RANGE: **90Vac** to **264Vac**.

2.2

RATED INPUT VOLTAGE: **100Vac** to **240Vac**.

2.3

INPUT FREQUENCY RANGE: **47Hz** to **63Hz**.

2.4

INPUT CURRENT: **0.5A** max. (I/P100-240Vac).

2.5

INRUSH CURRENT: **50A** max. at **100-240Vac** input for a cold start at 25°C.



3、 OUTPUT CHARACTERIST:

3.1 Power output

RATED OUTPUT	Min. Load	Rated Output Load	Output power	No Load Power consumption
5VDC	0 A	3A	15W	≤0.1W

3.2 Combined Load

RATED OUTPUT	Min. Load	Rated Output Load	Line Regulation	Load Regulation
5VDC	0 A	3A	±3%	(4.75V-5.25V)

3.3

Higher than 81.38% at 100-240Vac input and output (25%, 50%, 75% & 100% load.)

3.4 Ripple and Noise:

Under nominal voltage and nominal load,the ripple and noise are as follows when measure with Max.Bandwidth of 20MHz and Parallel 10uF/0.1uF,crossed connected at testing point.

<u>Voltage</u>	<u>Ripple and Noise(Max.)</u>
+5VDC	≤150mV p-p

3.5 Turn on delay time:

3Second Max.at 115Vac input and output Max.load.

3.6 Hold up time:

5 mS Min.at 115Vac input and output Max.Load.

3.7

Primary to Secondary AC3300V/10mA , 1 minute for type test. 3 second for production.

3.8 Overshoot:

10% Max.When power supply at turn or turn off.

4、 PROTECTION FEATURE :

4.1 OVER - CURRENT PROTECTION:

The green mode power supply shall be hiccupped when any output operating in overload condition(set@ Max load 110~130%) under any line condition for an indefinite period of time. The power supply shall be self - recovery when the fault condition is removed.

4.2 SHORT CIRCUIT PROTECTION:

The power supply shall be hiccupped and no damage shall occur when any output operating in a short circuit condition under any line condition for an indefinite period of time. The power supply shall be self - recovery when the fault condition is removed.

5、 ENVIRONMENTAL CONDITIONS:

5.1 OPERATING:

The power supply shall be capable of operating continuously in any mode without performance deterioration in the following environmental conditions.

5.1.1

Ambient Temperature: 0°C ~ 40°C

5.1.2

Relative Humidity: 10% ~ 90%

5.2Vibration

Operating: IEC 721-3-3 3M3 5~9Hz,A=1.5mm
(9~200Hz,Acceleration 5m/S²)

5.3 Cooling:

The power supply will operate with convection cooling .Blocking of vents must not cause damage to The power supply.

6、 Storage conditions:

The power supply shall be capable of withstanding the following environmental conditions extended periods of time, without sustaining electrical or mechanical damage and subsequent operational deficiencies:

6.1.1

Storage Temperature: - 30°C ~ 70°C

6.1.2

Relative Humidity: 10% ~ 90%

6.2.3 Vibration and Shock:

The power supply shall be designed to withstand normal transportation vibration per MIL-STD-810D, method 514 and procedures X, as it s mounted in the chassis assembly and packed for shipping.

7、 RELIABILITY AND QUALITY CONTROL:

7.1 BURN-IN

The power supply shall undergo a minimum of 2 hours Burn-In test under full load at 40°C ~ ±5°C

7.2 COMPONENT DERATING:

Semiconductor junction temperatures shall not exceed the manufacturer ' s maximum thermal rating.

7.3

USB plug-in 5000 times.

7.4

Average trouble-free use time of adapter is 5000 hours.

8、 EMC STANDARDS:

8.1 EMI STANDARDS:

The power supply met the radiated and conducted emission requirements for FCC CLASS B.

8.2 EMS STANDARDS:

The power supply shall meet the following EMS standards:

EN 55035: 2017; Part 15 Subpart B, IC ICES-003

9、 Energy Saving (Level VI / Level 6):

9.1 CEC Test Report (CEC Table U-2 Standards for Power Supplies Effective July 1, 2008)

9.2 EUP Test Report (COMMISSION REGULATION (EC) No 278/2009)

9.3 MEPS (AS/NZS 4665.2-2005)

10、 INSULATION RESISTANCE:

Input to output: 50M OHM(500VDC)

11、 LEAKAGE CURRENT:

The leakage current shall be less than 0.25mA for class II when power supply is operated maximum input voltage and maximum load.

12、 MAJOR MEASURE EQUIPMENT:

A. AC SOURCE: AFC - 500W

B. POWER METER: CHROMA 2100

C. ELECTRONIC LOAD: PRODIGIT 3310C

D. OSCILLOSCOPE: TDS-2012B

E. DIGITAL MULTIMETER: Fluke 4.5

F. DC POWER: WYK - 6030

G. HI - POT TESTER: LANKE ELECTRONICS 7112

H. INSULATION RASISTANCE TESTER: YD2681A

PRODUCT OUTLINE DIMENSION

Unit / :mm

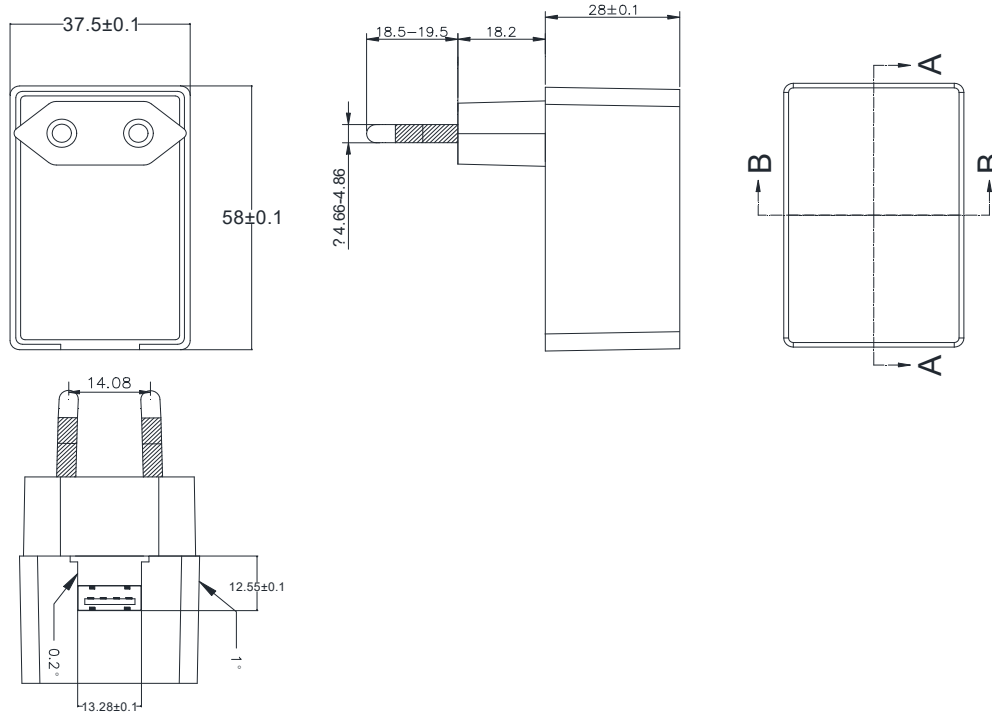

13、WEIGHT:

The weight of the power supply shall be about 51.8 g.

14、MECHANICAL REQUIREMENT:

The power supply size: L58*W37.5*H28mm.

15、COLOUR:

Black White

RATING LABEL

Unit:mm

Tolerance:+0/-0.2mm

직류전원장치(SMPS) 

모 델 명:XSD-0503000NEKU

정격입력:100-240VAC 50/60Hz 0.5A Max

정격출력:DC 5V 3000mA

제 조 원 : Shenzhen Sunshine Technological Co.,Ltd.

 HU101011-21005A
R-R-XSC-2400750

A/S연락처:XXXXX 제조년월: 년 월



MADE IN CHINA

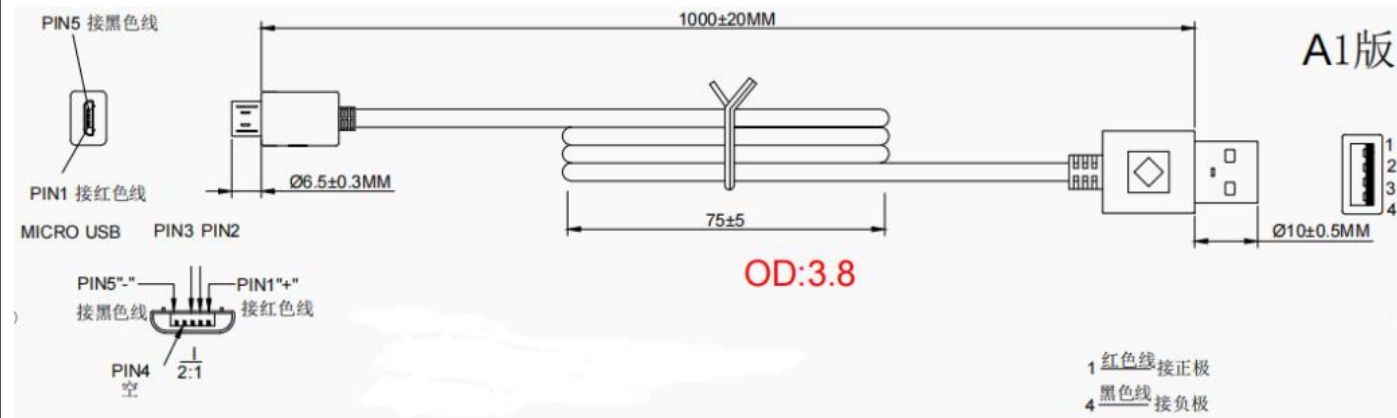

NOTE:

1. wire:UL 2464 18AWG VW-1 80°C 300V
2. Color: Black
3. Polarity: Black —●— red
4. Tensile test: lifting weight 20LBS, 60 seconds SR displacement less than 2mm;
5. Swing test: lifting weight 500g, 35~40 times per minute, 120° swing at least 500 times;
6. Wire hardness: DUROMETER TYPE A 70±10;

RATING LABEL

